

WIBRE

SPORTS POOLS

IN A

NEW LIGHT

**NEW RETROFIT INSERTS
FOR EXISTING POOLS**

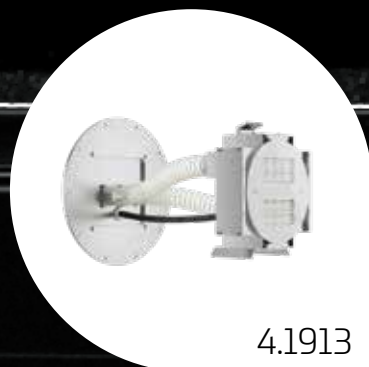

4.1913



4.2013

IS YOUR
COMPETITION POOL
STILL LIT WITH OLD
ENERGY-INEFFICIENT
SPOTLIGHTS?



THEN CHANGE THEM NOW.
NOT AT ALL COMPLICATED.



EASY AND FAST

REMOVE OLD HALOGEN INSERT

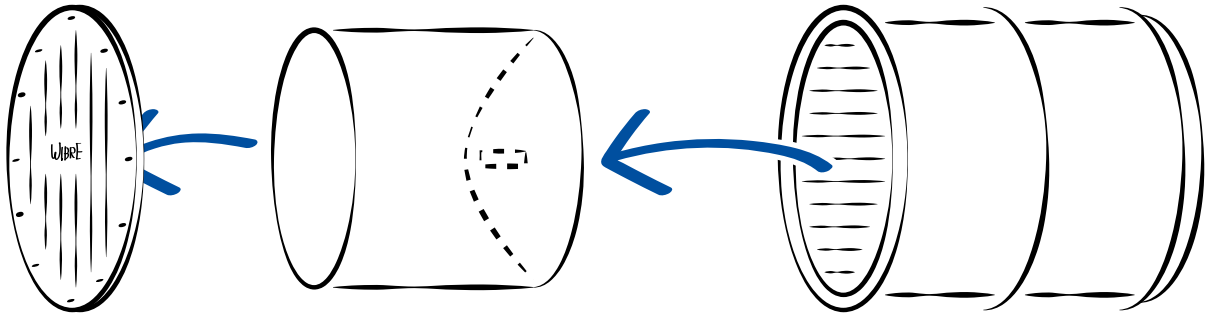

INSERT NEW LED INSERT AND CLOSE

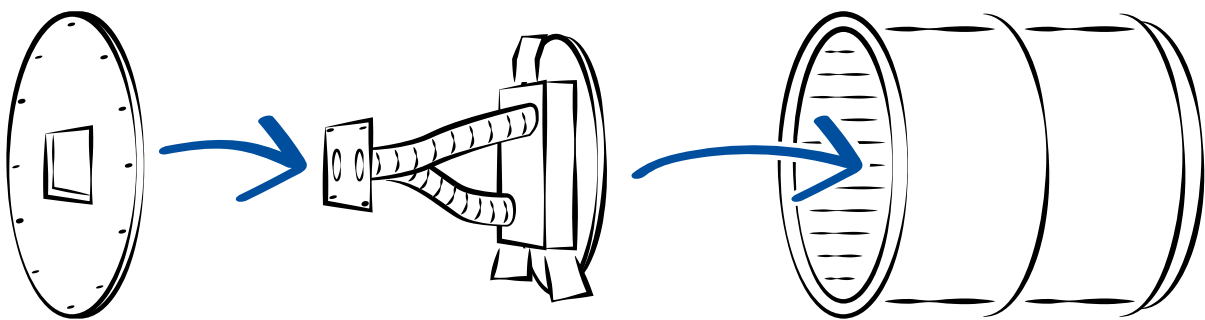

”

**EASIER THAN
CHANGING A LAMP,
AND WITHIN A
FEW MINUTES..**

AVANTAGES AT A GLANCE



5 YEARS WARRANTY

on the entire insert. More at www.wibre.de > Warranty



INDEPENDENTLY TESTED LIGHTING TECHNOLOGY

just recently by an approved lighting laboratory.

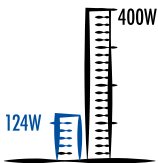

ALMOST 70 % LESS ENERGY CONSUMPTION

compared to the previous 400W light sources.

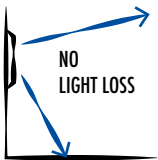

100 % FORWARD DIRECTED LIGHT

minimises the light loss.



ACTIVE COOLING BY FRESH AIR SUPPLY

An effective and controlled cooling of the LED unit.

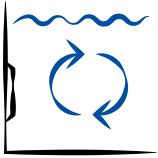

CHANGE POSSIBLE DURING OPERATION

to avoid idling.



INCREASE ATTRACTIVENESS, THANKS TO RGB-W

Ideal for events or therapies as well as for adventure pools.



COMPLIANT AND SAFE, AS A CLOSED UNIT

Thus conforming to regulations for public pools.

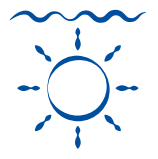

CAREFREE PACKAGE: CONTINUED PLEASURE

No need to change lamps, no maintenance costs.



INSTALLATION IN ONLY 5 STEPS

Old out - New in - Cover on - Close inspection flap - Connection - Ready

”

We are delighted with the luminosity of the insert, the light looks much clearer than with HQI. The coloured lighting gives our pool a completely different dynamic, also with regard to the therapies which take place in the pool.

THOMAS GRÜNER, DISTRICT OFFICE BÖBLINGEN
INDOOR POOL AT FRIEDRICH-FRÖBEL-SCHULE HERRENBERG

”

In a competition pool with 24 floodlights, more than 6 KW less is consumed per hour. Calculated over the year, this is a considerable financial saving.

BENJAMIN PFENDT, HEAD OF MARKETING
WIBRE LEINGARTEN

”

Thanks to the new LED underwater spotlights from Wibre, our pool is bright and optimally illuminated. Delivery and conversion from halogen to LED was quick and without difficulty.

MICHAEL MOSER, ASSISTANT DIRECTOR OF HALLENBAD SZU
SCHOOL OFFICE OF THE PRINCIPALITY OF LIECHTENSTEIN

”

We at Sportbad Kornwestheim are thrilled about the new LED spotlights, which make the water shine in blue, green or purple. This makes doing laps even more of an enjoyable experience and at the same time saves a lot of electricity. .

S. CAPALIJA, ASSISTANT BATH OPERATIONS MANAGER
SPORTBAD KORNWESTHEIM

YOUR PLUS

SECURE ATTRACTIVE ADVANTAGES
IF YOU ORDER BY THE END OF MARCH 2021

1. REVIEW OF SITUATION AND LIGHT TEST ON SITE
2. SERVICE DURING INSTALLATION
3. PERSONAL RECHECK AFTER 6 MONTHS

GET INFORMATION NOW

GET INFORMATION IN PERSON AND
WITHOUT ANY COMMITMENT DIRECTLY
WITH OUR INSERT EXPERTS:

PHONE: 07131 9053-0
MAIL: INFO@WIBRE.DE

WIBRE

WIBRE ELEKTROGERÄTE
EDMUND BREUNINGER
GMBH & CO. KG

LIEBIGSTRASSE 9
74211 LEINGARTEN
GERMANY

0049 (0) 7131 9053-0
WWW.WIBRE.DE
INFO@WIBRE.DE

